

**GENERAL NOTE:**  
 All tanks are subject to a 2.5% tolerance on all dimensions.  
 Any internals (if shown) are for guidance only, and may vary due to individual specifications.

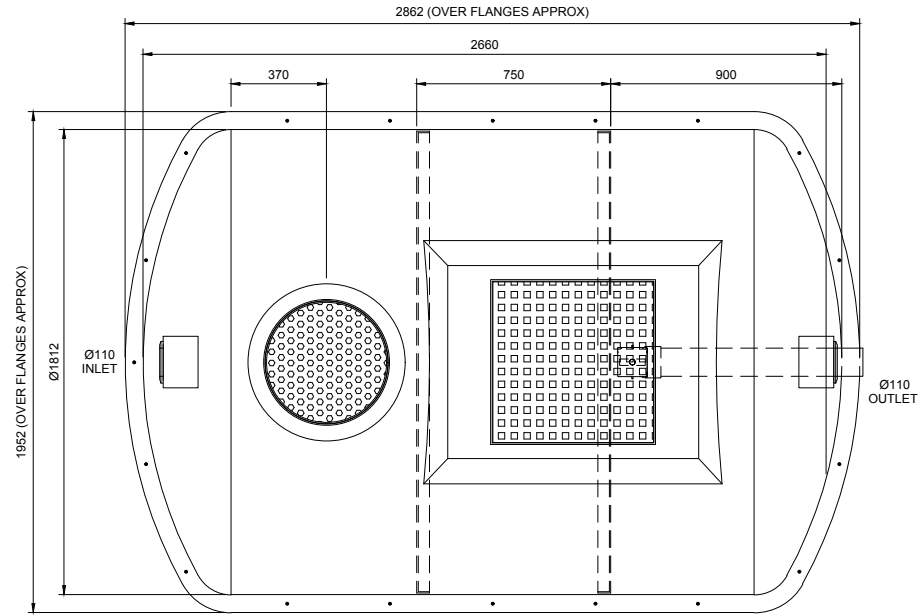

PLAN

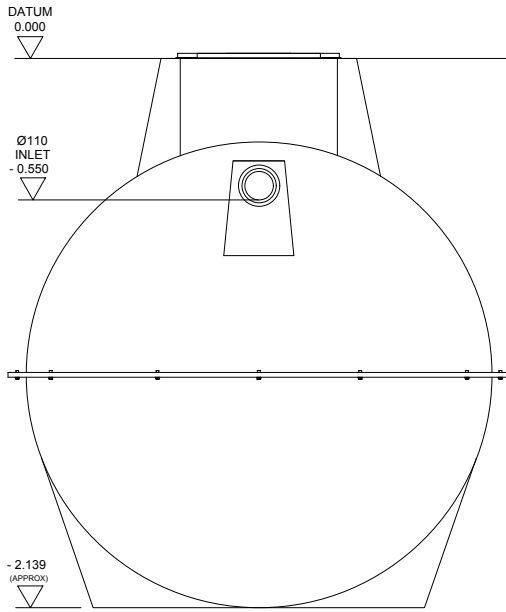

VIEW ON INLET

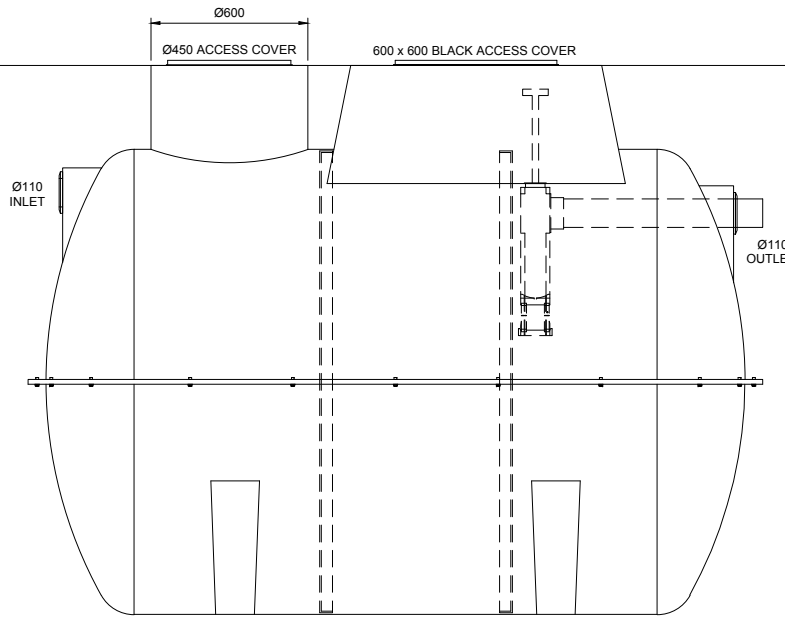

SIDE ELEVATION

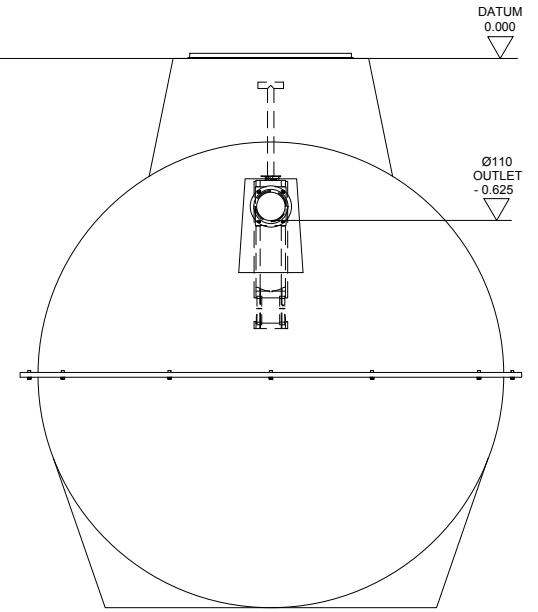

VIEW ON OUTLET

REV	DESCRIPTION	DATE	SIG	REV	DESCRIPTION	DATE	SIG	REV	DESCRIPTION	DATE	SIG
A	For Approval	01.07.14	P.L.								
B	600 DIA. TURRET OVER PRIMARY CHAMBER ADDED	05.03.21	K.H.								

THIS DRAWING IS THE PROPERTY OF MARSH INDUSTRIES LTD. AND MUST NOT BE REPRODUCED OR CIRCULATED FOR ANY PURPOSE WHATSOEVER WITHOUT FIRST OBTAINING WRITTEN CONSENT FROM THE MARSH INDUSTRIES LTD.		
DRG.	CHRD	APPD
SCALE	DATE	
N.T.S.	01.07.2014	
3 RD ANGLE PROJECTION		DO NOT SCALE IF IN DOUBT ASK

CLIENT  
 TITLE  
**MARSH ENSIGN ULTRA**  
**12PE (TWELVE PERSONS)**  
**GRAVITY OUTLET.**  
**EN12566-3:2011**

		<small>UNITS @ 13 ADDINGTON PARK IND. EST., LITTLE ADDINGTON, KETTERING, NORTHAMPTONSHIRE, NN14 4AS.</small>
		<small>DRG.</small> EN12 ULTRA STD <small>REV</small> B